

HEADEND AMPLIFIERS HAVE EVOLVED...

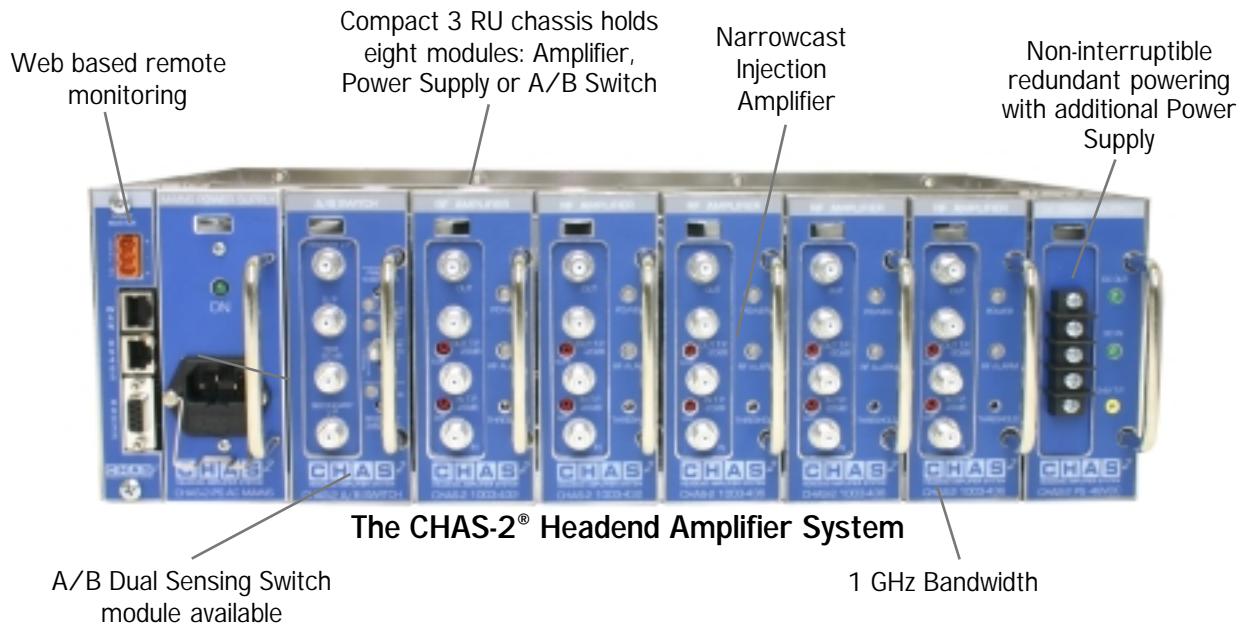

As opposed to other headend amplifier manufacturers that continue to offer the same designs year-after-year, the CHAS-2[®] Headend Amplifier System is designed to meet the *challenges of modern headends*. Our focus on customer needs and cutting-edge headend technology has produced the most advanced offering available. It is no surprise that CHAS-2 has also become one of the most utilized Headend Amplifier Systems in the Cable Industry.



Monitoring Capabilities:



CHAS 2[®] Monitor Interface Card - Master

The Amplifier Modules, A/B Switch and Chassis, can be activated for monitoring by installing the optional CHAS -2 CONTACT CLOSURE OR WEB MONITOR Interface Card.

- Access CHAS -2 remotely via web interface
- Monitor up to 32 chassis off a single Master Card
- Remotely monitor temperature, voltage, current, RF level and switch state

Amplifier Modules

- Excellent heat dissipation without fans
- Continuous gain and slope control allows adjustments without signal interruption
- Hot swappable
- Input test point or narrowcast input with the NI model
- Visual RF Level Alarm

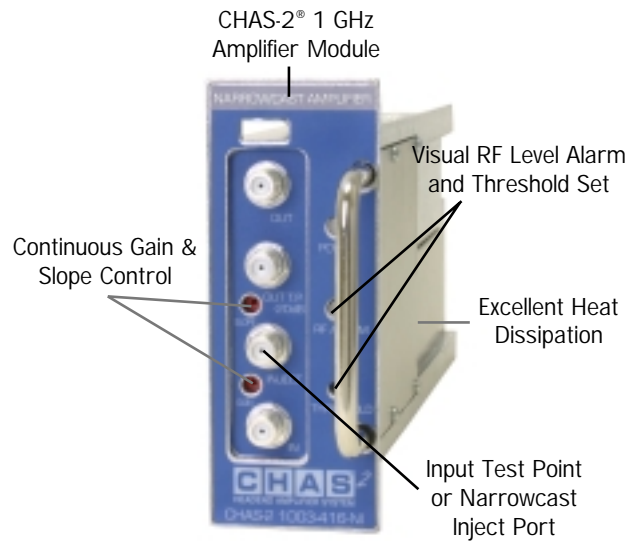

CHAS-2® Mains Power Supply



CHAS-2® -48VDC Power Supply



CHAS-2® Dual Sense A/B Switch

Part #	Part Description	Model Description
824-707-116-OCE	CHAS 2 1003MHZ 16DB AMP MODULE	CHAS-2-1003-416
824-707-120-OCE	CHAS 2 1003MHZ 20DB AMP MODULE	CHAS-2-1003-420
824-707-228-OCE	CHAS 2 1003MHZ 28DB AMP MODULE	CHAS-2-1003-428
824-707-232-OCE	CHAS 2 1003MHZ 32DB AMP MODULE	CHAS-2-1003-432
824-707-236-OCE	CHAS 2 1003MHZ 36DB AMP MODULE	CHAS-2-1003-436
824-707-016-OCE	CHAS 2 1003MHZ 16DB NI AMP MODULE	CHAS-2-1003-416-NI
824-707-020-OCE	CHAS 2 1003MHZ 20DB NI AMP MODULE	CHAS-2-1003-420-NI
824-707-422-OCE	CHAS 2 200MHZ 22DB AMP MODULE	CHAS-2-200-222
824-707-528-OCE	CHAS 2 50MHZ 28DB AMP MODULE	CHAS-2-050-228
824-707-600-OCE	CHAS 2 DUAL SENSE A/B SWITCH	CHAS-2 A/B SWITCH
824-707-602-OCE	CHAS 2 MONITORING CARD SLAVE	CHAS-2 SNMP-SLV
824-707-601-OCE	CHAS 2 MONITORING CARD MASTER	CHAS-2 SNMP-MSTR
824-707-700-OCE	CHAS 2 PWR SUPPLY 85-260VAC MAINS	CHAS-2-PS AC MAINS
824-707-701-OCE	CHAS 2 -48 VDC PWR SUPPLY	CHAS-2-PS -48VDC
824-707-800-OCE	CHAS 2 8-MODULE CHASSIS	CHAS-2 CHASSIS
824-707-802-OCE	CHAS 2 8-MODULE CHASSIS W/DC IN PANEL	CHAS-2 CHASSIS DC
824-707-801-OCE	CHAS 2 8-MODULE CHASSIS CNTCT CLSR	CHAS-2 CHASSIS CC
824-707-804-OCE	CHAS 2 8-MODULE CHASSIS WEB MONITOR	CHAS-2 CHASSIS WEB

CHAS²
HEADEND AMPLIFIER SYSTEM

June 2010

CableServ Inc.

4560 Eastgate Parkway
Mississauga, Ontario, Canada L4W 3W6
Telephone: (905) 629-1111
Fax: (905) 629-1115
Toll Free: 800-668-2033
E-mail to: inquiries@cableserv.com
Visit us at www.cableserv.com